

## CY40 Bridge Outline Dimensions

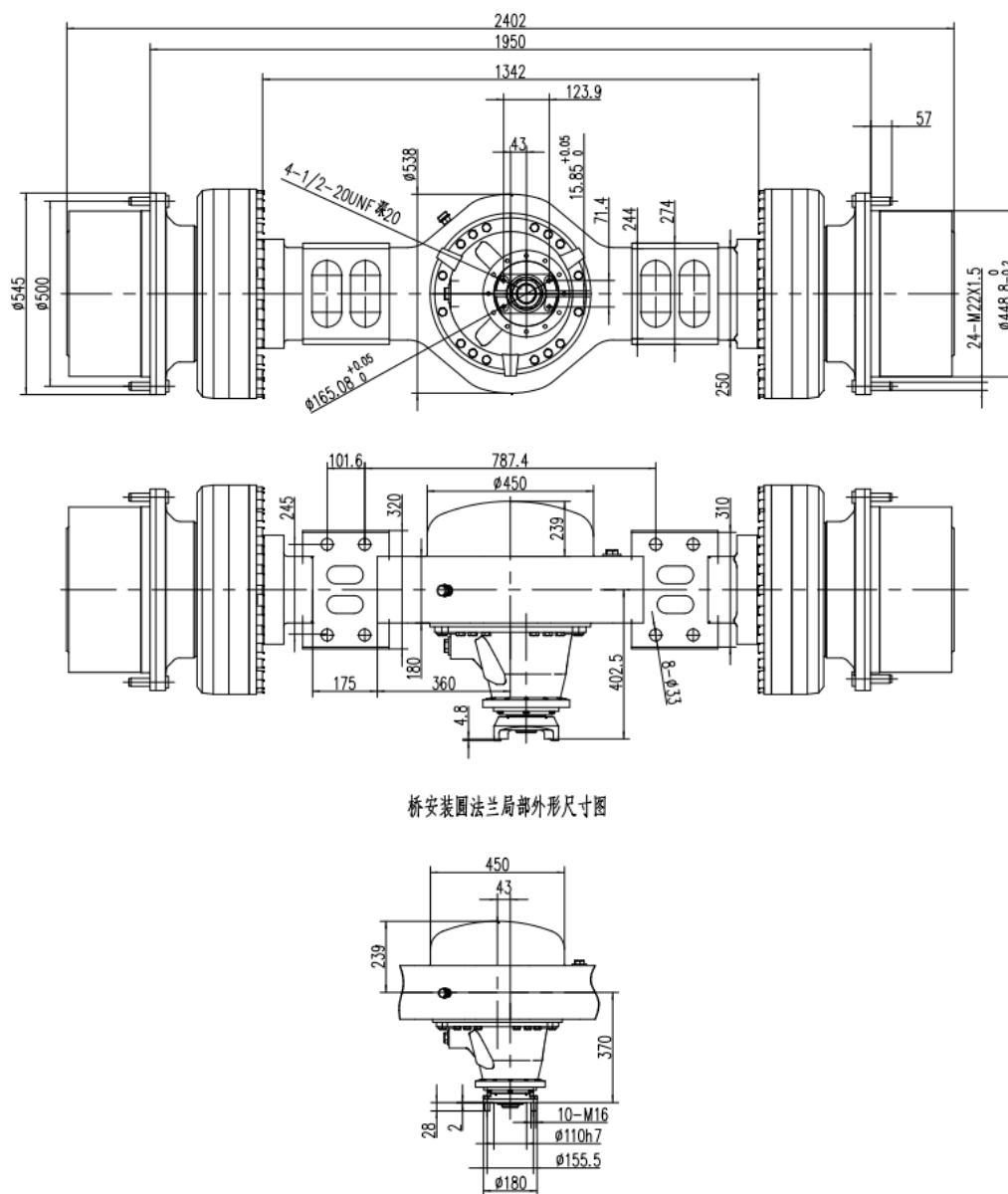

桥安装圆法兰局部外形尺寸图

The Chinese-made CY40 axle can replace the German Kessler D101 axle, and the internal parts of the axle are common

### Product performance parameter table

Parameter	Unit	Value
Braking torque (new friction)	N m	52000 -71600
Braking pressure (maximum)	N m	45600-62800
Brake spring compression force	N	240000
Release brake pressure	M pa	11~ 18
Colling pressure	M pa	0.07
Main reducer speed ratio		2.12 : 1
Speed ratio of wheel reducer		12.43 :1
Overall speed ratio		26.35 : 1
Maximum dynamic bearing	N	270500
Maximum static bearing capacity	N	1200000